

In-depth investigation of accidents and accident reconstruction

Alejandro Longton (Applus IDIADA, Spain)

P.Lesire (LAB, France), H. Johannsen (TUB, Germany), A. Fiorentino (FIAT, Italy),
P.Beillas (IFSTTAR), A. Kirk (Loughborough University, UK), B. Schnottale BAST,
Germany)

Abstract

The main objective of EC CASPER research project is to reduce fatalities and injuries of children travelling in cars. Accidents involving children were investigated, modelling of human being and tools for dummies were advanced, a survey for the diagnosis of child safety was carried out and demands and applications were analysed. From the many research tasks of the CASPER project, the intention of this paper is to address the following:

- In-depth investigation of accidents and accident reconstruction.

These will provide important points for the injury risk curve, in order to improve it.

Different accident investigation teams collected data from real road accidents, involving child car passengers, in five different European countries. Then, a selection of the most appropriate cases for the injury risk curve and the purposes of the project was made for an in-depth analysis. The final stage of this analysis was to conduct an accident reconstruction to validate the results obtained.

The in-depth analysis included on-scene accident investigation, creating virtual simulations of the accident/possible reconstruction, and conducting the reconstruction. In the cases of successful reconstructions, new points were introduced to the injury risk curves.

Accident reconstructions of selected cases were carried out in test laboratories as the next step following in-depth road accident investigation. These cases were reconstructed using similar child restraint systems (CRS) and the same type make and model as in the real accidents. Reconstructing real cases has several limitations, such as crash angle, cars' approximation paths and crash speed. However, a few changes and applications on the testing conditions were applied to reduce the limitations and improved the representations of the real accidents.

After conducting the reconstructions, a comparison between the deformations of the cars on the real accident and the vehicles from the reconstructions was made. Additionally, a correlation between the data captured from the dummies and the injury data from the real accident was sought. This finalises an in-depth analysis of the accident, which will provide new relevant points to the injury risk curve.

The CASPER project conducted a large research programme on child safety. On technical points, a promising research area is the developing injury risk curves as a result of in-depth accident investigations and reconstructions.

This abstract was written whilst the project was not yet finished and final results are not yet known, but they will be available by the time of the conference. All the works and findings will not necessarily be integrated in the industrial versions of evaluation tools as the CASPER project is a research program.

NOTATION

<i>EES</i>	Equivalent Energy Speed
<i>CASPER</i>	Child Advanced Safety Project for European Roads
T_0	The time at which the first impact between the cars occurs
<i>IRC</i>	Injury Risk Curves

INTRODUCTION

Since 1996, several European Union (EU) funded projects were carried out in order to improve child safety in cars. These projects remarkably enriched the knowledge of child safety in cars. Still, additional studies were required to fulfil the expectations in several fields.

The EC CASPER project built upon data from previous European research projects (mainly from EC CREST and EC CHILD) and included some investigation fields of others such as NPACS and EPOCH, with the aim to extend the knowledge on child protection, to improve the ratio of correctly restrained children and the understanding of the real life travelling conditions of children in cars. Moreover, the CASPER project also had a target to add to the knowledge on improving the effectiveness of the Child Restraint Systems (CRS).

A part of the work that was carried out in the CASPER project was in-depth investigation of accidents and accident reconstructions. This work provided important information that was used to fulfil the project database on road accident cases and to introduce new points for the Injury Risk Curves (IRC). Also, as a result of this work, an accident reconstruction database was enriched. Six accident investigation teams from five different European countries (France, Germany, Italy, Spain and UK) were established. A criteria method was developed for the selection of cases that are of interest for the project.

CASPER CASE SELECTION CRITERIA

The most important condition for collecting accident cases for the CASPER database was to have at least one restrained child passenger up to and including 13 years old (if the child is 13 years old it should be ≤ 150 cm tall). This requirement, explained more in detail below, is a result of the CASPER project's scientific goals.

For the purposes of the project, car-to-vehicle and car-to-fixed-object cases were considered with vehicles being passenger cars (or car derived small vans), designed for up to 9 occupants. Multi-purpose vehicles (MPVs) were also considered but minibuses with seats were not.

The accident investigation teams had to collect data on the way the child was restrained and what restraint system was used (CRS type or an adult seat belt). If a misuse was present the misuse had to be well defined in the case. If not, the accident was rejected. Also, the child or another restrained occupant had to have been seriously ($AIS \geq 2$) injured with injuries attributed to a frontal, lateral or rear impact.

Importantly, if this injury criteria was not met the case could still be included if some additional criteria were met:

- Delta V of minimum 40 km/h (for frontal impact)
- The intrusion on the passenger compartment has to be more than 200 mm (for lateral impact)

After the accident investigation teams collected information for the accidents, the data was reviewed to ensure that it complied with the project's goals or if the case can provide interesting information to

the project. Then, if approved, the cases were introduced in the anonymous CASPER accident database.

CASPER ACCIDENT DATABASE

The accident data collected in CASPER expanded the existing database with cases from previous European projects. As a result, the available database had information from 806 cases (1300 restrained children). It is also important to highlight that the Database is not representative of the overall European child car passenger population as a selection bias was used to collect the data (a bias for severe injuries was introduced). But it contains enough data to allow an indication of the body regions being injured in different CRS types or for different ages of children along with insights into how restraint conditions and the quality of use lead to injury (Kirk et al. 2012). On Figure 1 is shown the accident scene of an accepted CASPER case from Spain.



Figure 1: Vehicles on the accident scene of an accepted CASPER case from Spain

The cases that best fitted in the project's objectives and that could provide, through testing data capture, new data for the injury risk curves were selected to be considered for reconstructions. The proposed reconstruction had to be representative of the real accident and feasible to be carried out in a crash laboratory, making it as close as possible to the real accident.

SIMULATING THE ACCIDENT

After collecting the accident's data and having the case approved for a full scale reconstruction, a virtual simulation of the accident was carried out. This had to enhance the understanding of the accident conditions and to help for designing the reconstruction. Additionally, important information on the kinetics and kinematics of the accident was deduced. Other important information, such as Equivalent Energy Speed (EES), the overlap of the cars and the estimated Delta V, was extracted as the first approach to the reconstruction testing conditions.

SIMULATING THE ACCIDENT RECONSTRUCTION

One of the most important steps in preparing an accident reconstruction is to virtually simulate the test. By doing so, the similarity between the accident and the reconstruction test is verified. EES, kinetics and kinematics were compared. Additionally, different impact points were considered and the changes in kinetics and kinematics were examined. It was noted that even the smallest change in T_0 (the time at which the first impact between the cars occurs) can significantly affect the deformations, crash and post kinetics change the final position of the cars. The feasibility of the reconstruction in a crash laboratory and the possibility to carry it out with the available equipment was conformed.

ACCIDENT RECONSTRUCTION

According to some previous studies and database analysis it was agreed to focus on frontal and side impact test configurations. In this paper it is pointed out that if certain kinematics before the collision can affect substantively the kinetics of the occupants due to his combination of the vectorial x and y components of the velocities, they should be reproduced in the test. Simulation models and kinematics tools were developed in IDIADA in order to provide a better overview on the feasibility before to dismiss cases due to complexity. Once the final configuration of the test was determined, the actual test was prepared. The reconstructions were designed to be as close as possible to the real accidents, but to be feasible in a crash laboratory as well. In front of complex tests design, the final configurations were discussed with the CASPER partners' for the final decision on the reconstruction tests.

To carry out a successful accident reconstruction, several different elements had to be considered such as newly developed tools and the skills on testing grounds.

Test set-up

In crash testing laboratories there are usually three types of driving systems. The first one uses one trailing cable that is moving in one direction. The second system uses a cable that can move vehicles simultaneously in two opposite directions and, the third, a system, in which different dragging cables are placed at different angles to join the kinetics of the main trailing cable and allows to carry out compatibility crash tests. This system allows reconstructions and other crash tests to be carried out at different angles and different speeds. However, this system is very rare and expensive due to his large investment (see Figure 2).

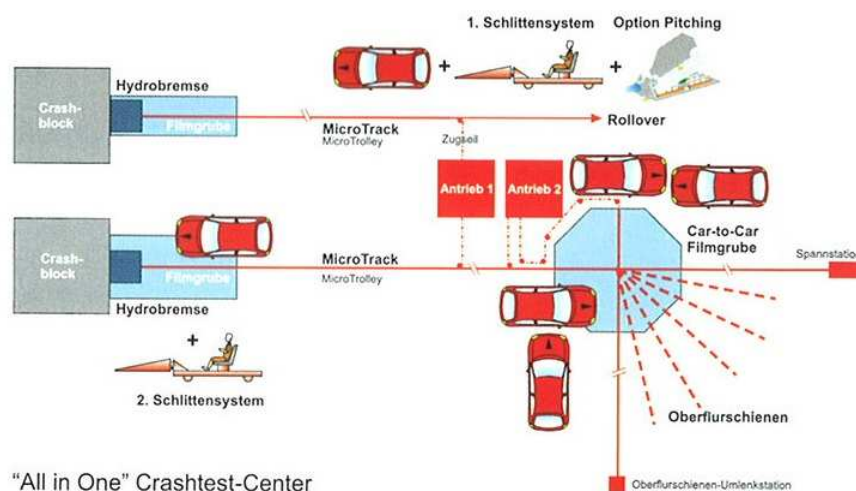

Figure 2: A comparison between different moving systems

The second system was the one that was used in the accident reconstructions at IDIADA. In this system a trailing cable that can simultaneously move vehicles in two opposite directions was used in combination with pulleys to reproduce collision angles and different impact velocities. The system is powered by an 500 kW direct current electric propulsion system, capable of dragging one vehicle of 3,5 ton up to 110km/h or two vehicles of 3,5 tons up to 65 km/h each.

For the tests considered as complex cases because they are not following the common configuration on which there are two cars being dragged in two movements but on opposite directions, there are some key parameters to keep under control:

Pulleys

To carry out reconstructions at an angle different than 180° , pulleys were used. For example, in the accident reconstruction' configuration, shown at Figure 3, pulleys were used to achieve a crash angle of 240° and a pulley system to crash the vehicles at different speeds. Using pulleys can increase or decrease the velocity of one of the cars.

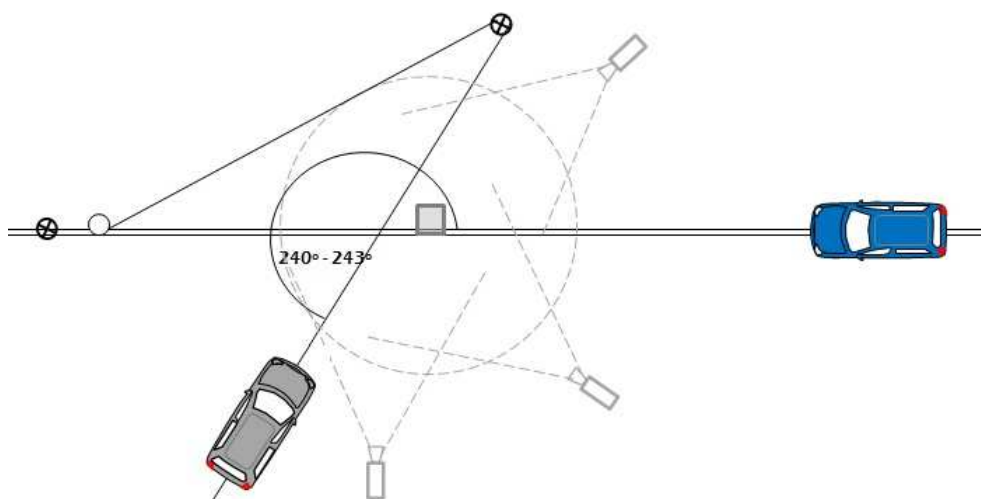

Figure 3: Accident reconstruction's configuration

Elasticity

The trailing cables have different elasticity. Usually, this is not a key issue that can influence the test. However, in some of the CASPER accident reconstructions this was of high importance due to the length need to reach the impact velocity. A trailing cable with a smaller elasticity had to be used as the trailing cables that are usually used could cause reaching the system's resonance frequencies.

Release of dragging cables

For certain complex test configurations, when pulley systems were used and the paths of the vehicles were crossing, the dragging cables could affect the kinematics of the opposite cars, especially after the first impact. Sometimes special systems for releasing trailing cables were designed and built up in order to reduce the risk of interaction on the car kinetics and the effects on the occupants.

Motor power

The whole system needs to be powered by a system's capacity able absorb the intensity peaks when an electric engine is used. When pulleys are used the friction of the whole system is increased and therefore the engine can require to solve higher electric intensity peaks at the beginning of a crash test to set the system in motion. Therefore, it had to be ensured that the electrical features of the crash ground can power the test configuration without any problems.

Test trials

Some of the more complex test configurations required test trials to be carried out as part of test design and development in order to ensure that the real accident reconstruction would run smoothly.

Position at T_0

Another very important point for a successful reconstruction is to ensure the cars position at T_0 . As already said in the "Simulating the accident reconstruction" section, even the smallest difference in the car position at T_0 can change the kinematics of the accident.

Vehicles and CRS

It was required that the vehicles should be equipped with at least one tri-axial accelerometer in order to check the test pulse and that from the simulation models. As for the child restraint, at least two accelerometers were installed in the reconstructions in each CRS, a tri-axial and a uniaxial, depending on the configuration of the reconstruction.

The occupants

Dummies

The main purpose for the in-depth accident investigation and for carrying out accident reconstructions was to correlate the medical injuries with the dummies' readings after validation of the reconstruction accuracy. The Q-dummies were used in the CASPER project. The dummy that was closest to the age of the child was used as only dummies representing a certain age are available. The sensors available for these dummies are given in Table 1.

Instrumentation		Dummies					
Sensor	Region	Q0	P0	Q1 / Q1½	P1½	Q3 / Q6	P3 / P6
3-axis accelerometers	Head	✓		✓	✓	✓	✓
	Thorax	✓		✓	✓	✓	✓
	Pelvis	✓		✓	✓	✓	
6-axis load cell	Upper neck	✓		✓	✓	✓	✓
	Lower neck				✓	✓	
	Lumbar spine			✓	✓	✓	
3-axis angular rate sensor	Head			✓		✓	
Displacement sensor	Chest			✓	✓	✓	

Table 1: Q-dummies sensors available for reconstructions (P/Q dummies comparison, Longton, 2011)

Occupants' positioning

The CASPER project was interested only in children's injury data. However, sometimes data from other passengers was collected as well. This data was used as an additional validation tool.

The occupants' positioning in the reconstruction was as close as possible to the actual crash positions. However, in some cases the adult occupants were replaced by the equivalent weights. This was done as some accident reconstructions lead to extreme car deformations and may endanger the dummies. All of the children were always represented in the accident reconstructions as this was the main aim of the CASPER project.

Injuries

Before conducting an accident reconstruction, the injuries from the real accident were taken into close consideration. This was done in order to ensure that the dummies' equipment would capture as much data as possible from the areas of interest (the injured body regions). After the reconstruction, the real injuries were correlated with the dummies' readings. In Figure 4 is shown a comparison between the real injuries (child approaching 2 years old) and the dummy's (Q1.5) readings.

SEATING POSITION:		Age:
Rear center		approaching 2 years old
Type of restraint:	Use	M.AIS
CRS group 1	Yes	4
Injuries		
Injury	Cause	AIS code
head injury description	Deceleration	X.X.06.84.3
GSC=3	Deceleration	X.X.08.04.4
lumber spine injury descr.	Head/chest movement	X.X.02.30.2
lumber spine injury descr.	Head/chest movement	X.X.02.02.3
Thorax injury description	Harness	X.X.18.02.3
Thorax injury description	Harness	X.X.14.10.4
lumber spine injury descr.		X.X.04.01.3
DIED xx DAYS AFTER THE ACCIDENT		

Body region	Max. Values	
Head	Acceleration X	29.59g
	Acceleration Y	9.826g
	Acceleration Z	66.39g
	Resultant Acc.	70.17g
	HIC 36 ms	499.98
	Angular speed X	854.9deg/s
	Angular speed Y	2226deg/s
Chest	Angular speed Z	806.7deg/s
	Resultant ang. Sp.	2277deg/s
	Acceleration X	37.35g
	Acceleration Y	17.78g
	Acceleration Z	21.58g
Neck	Resultant Acc.	38.69g
	XMS 3ms Cumul.	34.75
	Fx	440.0N
	Fy	250.0N
	Fz	115.0N
	Resultant F	1181N
	Mx	5.830Nm
	My	13.94Nm
Neck	Mz	3.100Nm
	Resultant M	14.73Nm

Figure 4: A comparison between real injuries from a CASPER accident (European) and dummy readings

Additionally to the pure mathematical comparison of the dummies' readings to the real injuries, videos of cameras inside and outside the cars were reviewed, especially when strange behaviour is detected and to check overall dummy kinematics. Paint was placed on the dummies' heads so that any impact can be noticed.

DEFORMATION CODING

In order to standardise the descriptions of the deformations of the crashed vehicles, the Collision Deformation Classification (CDC) was used. This codification system is used by most of the accident investigation teams and it consists of eight fields, explaining clearly the deformation of a car in a collision (Collision Deformation). CDC coding of the real accident and the reconstructions could be compared in order to review the accuracy of the test, to help validating the accident reconstruction. Further detail is recorded of measurements of deformation and intrusion at specific important points on the vehicle (for example, right/left side frontal longitudinal deformation, mid-door lateral intrusion). These are important points as they indicate deformation of stiff vehicle structures and intrusion that can influence occupant injuries. These accident vehicle measurements are compared to the same points on crash test vehicles.

FINAL RESULTS AND ANALYSIS

After the tests, several analyses take place. The kinematics of the occupants in the cars were reviewed by synchronizing videos and dummy readings as a way to ensure the validation of the data as they will be correlated with the real injuries. Car pictures and test videos are reviewed and compared with the accident evidence and simulation models in a feedback process.

When the reconstruction tests and the data capture are approved, the CASPER reconstruction database is fulfilled and further analysis take place. On this topic and considering the dummy's scaling rules, the data are analysed from statistical point of view in order to allow new points to be considered in the injury risk curve for the different child ages and body regions

CONCLUSIONS

As required for the simulation models, the more information that can be collected and deduced from the real accident evidence, the better the reconstruction test design. Skills and experiences in this field contribute substantially to success in the test performance as many unexpected situations can arise. These are challenging real world accidents, very often away from standard crash test conditions in terms of severity, collision angles and dummy set up.

For certain complex test configurations, when pulley systems were used, it is common to consider avoiding the interaction between the dragging cables and the kinematic of the vehicles. Also, some special situations could occur when, e.g. one vehicle can be caught by the other one during the collision and affect the kinematics after this first impact. This would affect the kinematic of the occupants.

As a result of the experience from reconstructing real accidents, it can be concluded that the correct positioning of the vehicles at T0 was highly sensitive. Even the smallest change when running the tests could result in a big drift of the results.

REFERENCES

1. Kirk, A, Lesire, P, Schick, S (April 2012) Road Reality Status (Fatality studies), Deliverable 3.2.1 of the EC FP7 Project CASPER
2. Kirk at al., (2012) Report on Accident Analysis, Deliverable 3.2.3 of the EC FP7 Project CASPER
3. Ernst Tomasch, Graz University of Technology, AT. ‘Accident Reconstruction Guidelines, Part of Deliverable D4’, EC PENDANT Project, October 2004
4. Collision Deformation Classification – SAE J224 MAR80

Acknowledgments

The CASPER project is co-funded by the European Commission under the 7th Framework Programme (Grant Agreement no. 218564).

The members of the CASPER consortium are: GIE RE PR - PSA/RENAULT, Technische Universität Berlin, Université de Strasbourg, APPLUS IDIADA Automotive SA, IFSTTAR, Loughborough University, FIAT Group Automobiles Spa, Medizinische Hochschule Hannover, Chalmers tekniska högskola AB, Bundesanstalt für Straßenwesen, TNO, Verein für Fahrzeugsicherheit Berlin e.V., Ludwigs Maximilian Universität, Centre Européen d’Etudes de Sécurité et d’Analyse des Risques, Humanetics Europe GmbH. Further information is available at the CASPER web sites: www.childincarsafety.eu and www.casper-project.eu.

The partners wish to acknowledge all the CREST/CHILD and CASPER data collection teams and their sponsors from all the countries involved in this work.

UK Loughborough cases, collected during the EC CREST/CHILD projects, include accident data from the United Kingdom Co-operative Crash Injury Study, collected up to 2006. CCIS was managed by TRL Ltd on behalf of the Department for Transport (Transport Technology and Standards Division) who funded the project with Autoliv, Ford Motor Company, Nissan Motor Europe and Toyota Motor Europe. The data were collected by teams from the Birmingham Automotive Safety Centre of the University of Birmingham, the Vehicle Safety Research Centre at Loughborough University, and the Vehicle & Operator Services Agency of the Department for Transport. The views expressed in this work are those of the authors and not necessarily those of the UK CCIS sponsors.